



PSCL12030
PSCL 12V/3A switch
mode power supply



Edition: 3 from 14.01.2020
 Supersedes edition: 2 from 13.10.2014

EN

Features of the power supply unit:

- power output 3 A/12 V DC*
- universal AC input voltage range 90÷264 V
- high efficiency 83%
- standby power <0,3W
- efficiency level: V
- IP 67 case
- protections:
 - SCP short-circuit protection
 - overvoltage protection (AC input)
 - overload (OLP)
- warranty – 2 year from the production date

1. Technical description.

1.1. General description.

Stabilized DC power supply is intended for supply equipments that require stabilised voltage of **12 V DC**. When connected to fuse blocks of the LB4/xx/xx family, the power supply unit can feed more equipments (max. 4). The power supply unit is protected against short-circuit, overload and overvoltage.

1.2. Specifications.

Supply voltage	90 ÷ 264 V AC 50÷60Hz
Current consumption	0,37 A@ 230 V max.
Supply power	36 W max.
Efficiency	83%
Output voltage	12 V DC
Output current $t_{AMB}<30^{\circ}C$	3 A - refer to graph 1.
Output current $t_{AMB}=40^{\circ}C$	2,1 A - refer to graph 1.
Ripple voltage	100mV p-p max.
Short-circuit protection SCP	electronic, automatic recovery
Overload protection OLP	150-200% of power supply, automatic recovery
IP protection class	IP67
Operation conditions	temperature $-10^{\circ}C \div +40^{\circ}C$ relative humidity 20%...90% without condensation
Dimensions (LxWxH)	135 x 50 x33 [mm]
Net/gross weight	0,31kg / 0,34kg
Protection class PN-EN 60950-1:2007	II (second)
Length of DC cable	0,5 m + DC plug 5,5 / 2,1 female
Length of AC cable	0,3 m
Storage temperature	$-20^{\circ}C \dots +60^{\circ}C$

* In order to extend the life of the power supply, the load current of 2,1 A is recommended.

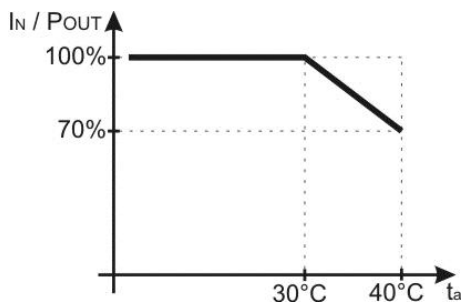

Graph 1.
 Relation between output current and ambient temperature (instantaneous load).

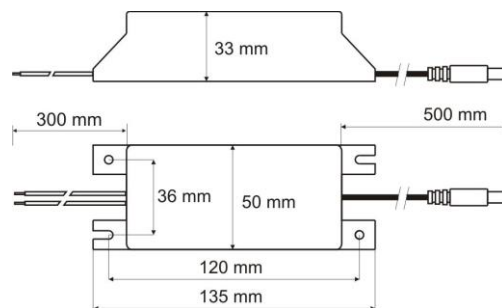

Fig.1. Dimensions of power supply.

* Refer to graph 1

1.3. Accessories.

For the power supplies are available accessories - fuse blocks and cable adapter. For details –visit www.pulsar.pl

2. Installation.

2.1. Requirements.

The power supply shall be mounted by the qualified installer having appropriate (required and necessary for a given country) permissions and qualifications for connecting (operating) low-voltage installations. The power supply shall be mounted in closed rooms, according to the environment class II, of the normal air humidity (RH=90% max.) and the temperature within the range from -10°C to +40°C.

In order to fulfill LVD and EMC requirements the rules for power supplies, encasing and shielding shall be observed according to application.

2.2. Installation procedure.

1. Connect the DC output to the load/loads.
2. Connect the power supply to the AC line. The power supply has to be installed in such way to keep the air flow around the supply unit.
3. After tests and operation control are performed, the casing (cubicle) shall be closed etc.

3. Maintenance.

Any and all maintenance operations may be performed following the disconnection of the power supply from the power network. The power supply does not require any specific maintenance procedures, however, in the case of significant level of dust, it should be cleaned with the compressed air.



WEEE designation

The waste electric and electronic equipment worn out may not be disposed of together with standard household waste. According to the WEEE directive, applicable in the EU, the separate neutralization methods should be used for electric and electronic equipment.

Pulsar sp. j.

Siedlec 150, 32-744 Łapczyca, Poland
Tel. (+48) 14-610-19-40, Fax. (+48) 14-610-19-50
e-mail: biuro@pulsar.pl, sales@pulsar.pl
http:// www.pulsar.pl, www.zasilacze.pl